

First result using Angle Resolved Photoelectron Spectroscopy Beamline at Indus-1

S.N. Jha, N. C. Das, S.V.N. Bhaskara Rao, B.N. Rajasekhar, Jagannath, A.V. Korgaonkar and V.C. Sahani

Bhabha Atomic Research Centre, Mumbai-400 085

snjha@cat.ernet.in

Abstract

A beamline for angle resolved photoelectron spectroscopy (ARPES) has been recently commissioned at Indus-1 synchrotron radiation source, Centre for Advanced Technology, Indore. The beamline-optics consists of a pre-focussing toroidal mirror, 1.4 meter toroidal grating monochromator (TGM) and a post-focussing toroidal mirror to cover the spectral region of 40Å to 1000Å. The beamline is coupled with the ARPES experimental station and it will be used for recording photoelectron spectra of various kinds of solids for studying their electronic band structure.

INTRODUCTION

Angle resolved photoelectron spectroscopy (ARPES) is a unique tool to map the energy dispersion curves of electrons in solids. Angle resolved photoemission experiments need a high flux for which the present ARPES beamline at Indus-I synchrotron is ideally suited. We report here typical gold and stainless steel photoelectron spectra which have been recently recorded using this beamline.

BEAMLINE DESCRIPTION

The heart of the beamline is a 1.4meter toroidal grating monochromator (Jobin Yvon-TGM-1400) with resolving power of

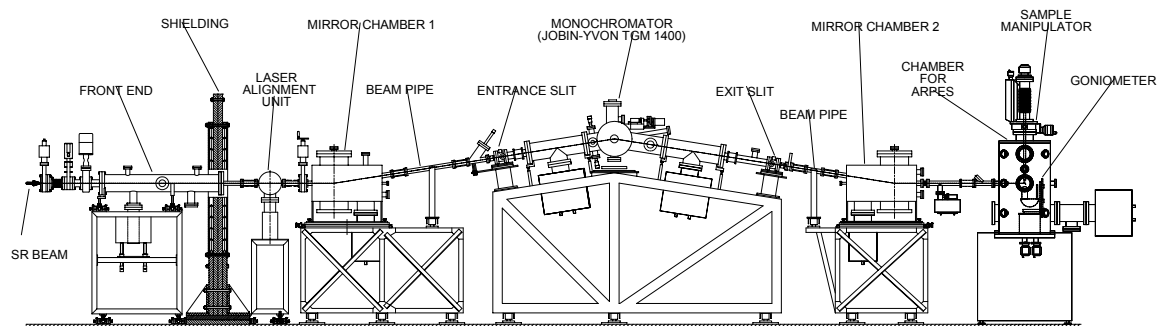

Fig.1: Mechanical lay-out of ARPES beamline

400 in the wavelength region of 40 to 1000Å. The monochromator consists of three interchangeable gratings to cover the entire wavelength region. The optics of the beamline consists of a pre-focussing mirror, monochromator with entrance and exit slits, gratings, and refocusing mirror. All the focussing optical elements have toroidal shapes and are coated with platinum on bulk zerodur material. The mechanical layout of the beamline which has been finalised on the basis of optical layout¹ has been shown in fig.1.

PHOTOEMISSION MEASUREMENT:

Photoemission spectrum was recorded using toroidal grating of 1800 grooves /mm of groove density in the photon energy range of 124eV to 310 eV. The monochromator was kept initially at high throughput settings and several survey scans of photoelectron spectra of gold and stainless-steel(S.S-304) samples were taken with an electron pass energy 30eV. During the recording of photoemission spectra the base pressure in the experimental chamber was maintained at 1×10^{-9} Torr or below.

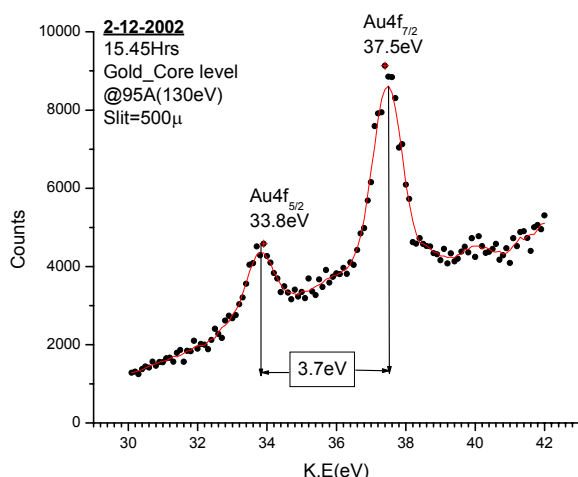

Fig.2. PES Spectrum of gold

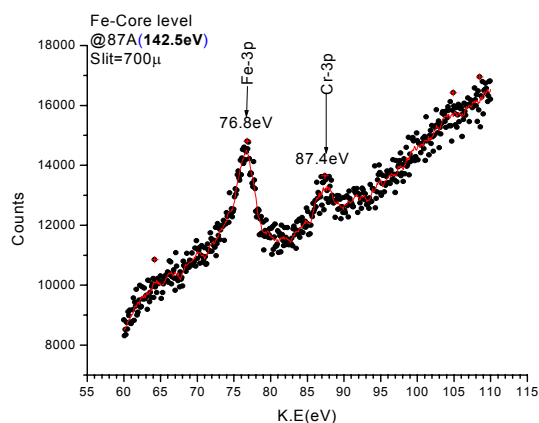

Fig.3: PES Spectrum of S.S. 304

A gold sheet mounted on the sample holder is first cleaned with Argon ion sputter etch gun at an energy of 4 keV ion beam for about half an hour and then spectra are taken after ensuring the cleanliness of the sample by recording the gold Auger spectrum. In Fig.2, a recorded spectrum of the sample is shown which is taken using a photon beam corresponding to 95Å. The spectrum was taken at a pass energy 30 eV. The angular acceptance of the analyser is 1° which is the requirement of the angle resolved PES studies. The separation between the kinetic energies of the two peaks is 3.7 eV which agrees with the corresponding value as given in standard literature. Using the above mentioned procedure, we recorded the spectra of stainless steel (S.S. 304L) sample. Fig. 3 shows the spectrum of the SS sample where the distinct features of Fe 3p and Cr 3p lines may be observed.

ACKNOWLEDGEMENT

We acknowledge the very useful cooperation rendered by members of SUS section and Workshops of Centre for Advanced Technology, Indore. We are grateful to Dr. S.K. Sikka, former Director, A.&C.M.P.Group, Bhabha Atomic Research Centre, Mumbai and Dr. D.D. Bhawalkar, Director, C.A.T., Indore for their continuous encouragement during the development of this beamline.

REFERENCES

1. N.C. Das, S.N.Jha and B.N. Rajasekhar, "Optical design of Angle Resolved Photoelectron Spectroscopy Beamline at Indus-1 Synchrotron Radiation Source" Journal of Optics, Vol.31, 129 (2002)

